

备注

- 1、设备为金属外壳时VGA外壳要与PGND直接连接；
- 2、磁珠、电容的选用参数根据实际测试结果来调整。

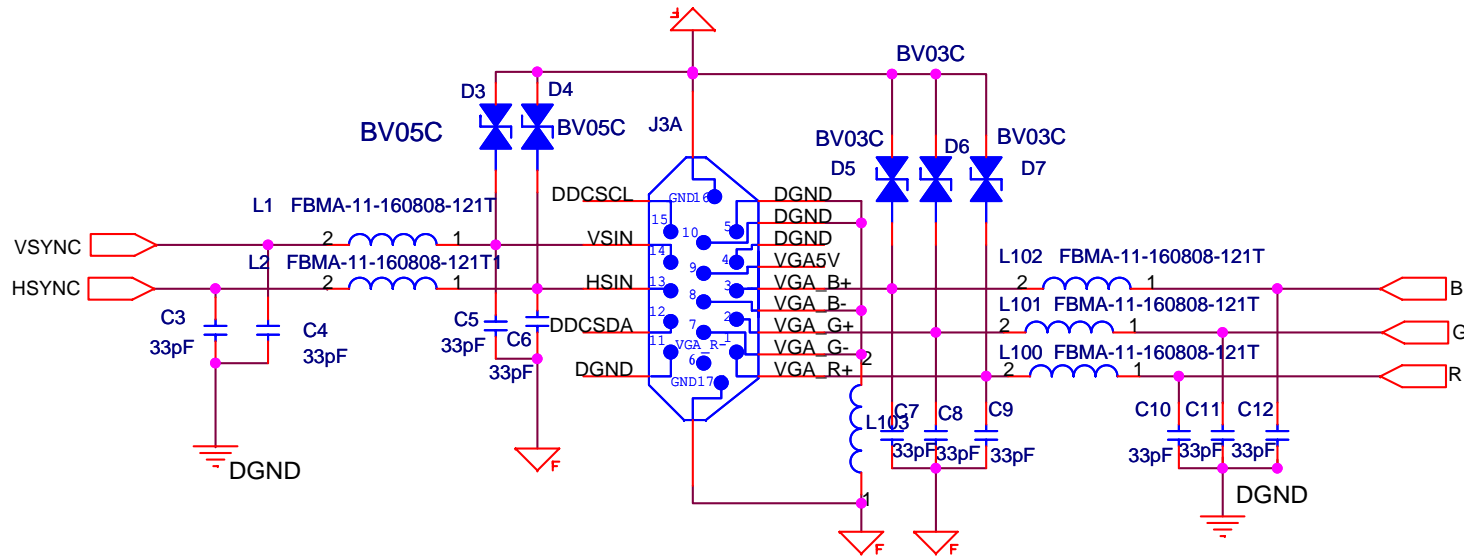

一站式电磁兼容 (EMC) 方案供应商

电话: 钟凯13632524150; 0755-26532285

邮箱: kai.zhong@compon-tech.com

Title
2285

VGAEMC设计标准电路

Size Document Number

A

Compon20110322-7

Rev
1.0

Date: Wednesday, October 26, 2011

Sheet 1 of 1